

Warnhinweise
Warnings
Recommandations
Avvertenze
Advertencias

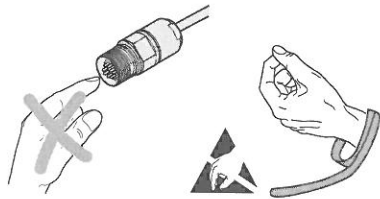

Achtung: Die Montage und Inbetriebnahme ist von einer qualifizierten Fachkraft unter Beachtung der örtlichen Sicherheitsvorschriften vorzunehmen.
 Zusätzlich muss der Maschinenhersteller/-konstrukteur die erforderlichen weiteren Angaben zur Endmontage (z.B. Losdreh Sicherung für Schrauben ja/nein) für die jeweilige Anwendung selbst festlegen.
 Die Steckverbindung darf nur spannungsfrei verbunden oder gelöst werden.
 Die Anlage muss spannungsfrei geschaltet sein!

Note: Mounting and commissioning is to be conducted by a qualified specialist under compliance with local safety regulations.
 In addition to this, the machine manufacturer or designer himself must define the other data required for final assembly (e.g. anti-rotation lock for screws required or not) for the respective application.
 Do not engage or disengage any connections while under power.
 The system must be disconnected from power.

Attention: le montage et la mise en service doivent être assurés par un personnel qualifié dans le respect des consignes de sécurité locales.
 D'autre part, le fabricant/constructeur de la machine doit définir d'autres données nécessaires au montage final (p.ex. sécurité frein de vis oui/non) pour l'application respective.
 Le connecteur ne doit être connecté ou déconnecté qu'hors potentiel.
 L'équipement doit être connecté hors potentiel!

Attenzione: Il montaggio e la messa in funzione devono essere eseguite da personale qualificato nel rispetto delle norme di sicurezza locali.
 Inoltre, il costruttore della macchina deve definire le ulteriori procedure necessarie per completare il montaggio (ad esempio: sicurezza allentamento viti sì/no) di ogni specifica applicazione.
 I cavi possono essere collegati o scollegati solo in assenza di tensione.
 L'impianto deve essere spento!

Atención: El montaje y la puesta en marcha deben ser realizados por un especialista cualificado, observando las prescripciones locales de seguridad.
 Adicionalmente, el fabricante/constructor de la máquina debe determinar él mismo el resto de indicaciones requeridas para el montaje final para cada aplicación en particular (p.ej., seguro antigiro para tornillos sí/no).
 Conectar o desconectar el conector sólo en ausencia de tensión.
 ¡La instalación debe ser conectada en ausencia de tensión!

Biegeradius Kabel **R**
 Bending radius Cables **R**
 Rayon de courbure **R**
 Piegatura **R**
 Radio de curvatura **R**

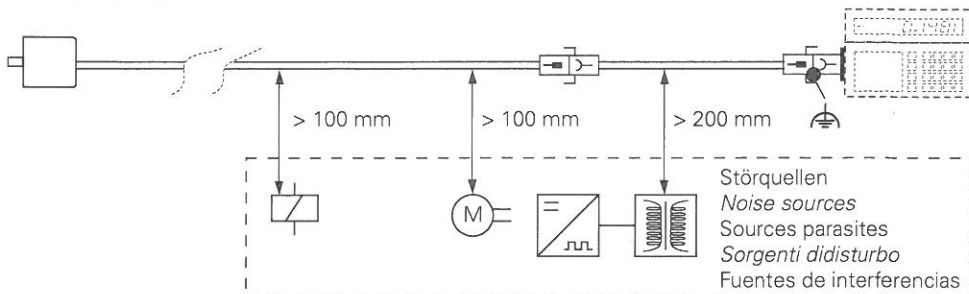
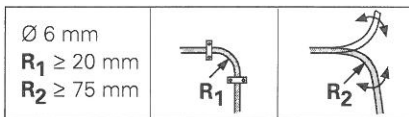

ROD 426 TTL
ROD 436 HTL
ROD 466 TTL
ROD 476 TTL
ROD 486 1 VSS

Drehgeber für separate Wellenkupplung.
 Rotary encoders for separate shaft coupling.
 Capteurs rotatifs pour accouplement d'arbre séparé.
 Encoder con giunto albero separato.
 Generador rotativo acoplamiento al eje por separado.

HEIDENHAIN

Montageanleitung
 Mounting Instructions
 Instructions de montage
 Istruzioni di montaggio
 Instrucciones de montaje

ROD 4x6

WELLA1: 73A
 FLANA1: 01C
 ANELA1: 01, xxS12, 7NS12
 BELEA1: 03

11/2012



Lieferumfang:
Items supplied:
Objet de la fourniture:
Standard di fornitura:
Suministro:



Separat bestellen:
 Order separately:
 Commander séparément:
 Ordinare separatamente:
 Pedir por separado:



Spannpratzen (3 Stück nötig)
 Fixing clamps (3 required)
 Griffes de montage (3 pièces nécessaires)
 Graffette (necessari 3 pezzi)
 Mordazas (se requieren 3 piezas)
 ID 200032-01

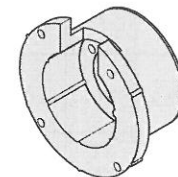

Montageglocke
 Adapter flange
 Cloche de montage
 Campana di montaggio
 Campana de montaje
 ID 257044-01

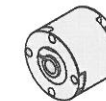

Membrankupplung K 17
 Diaphragm coupling K 17
 Accouplement à membrane K 17
 Giunto a membrana K 17
 Acoplamiento de membrana K17
 ID 296746-xx

DR. JOHANNES HEIDENHAIN GmbH

Technical support, measuring systems ☎ +49 8669 31-3104 · E-mail: service.ms-support@heidenhain.de



Anbaumaße (mm)
Mounting Dimensions (mm)
Cote d'encombrement (mm)
Dimensioni di montaggio (mm)
Medidas para el montaje (mm)

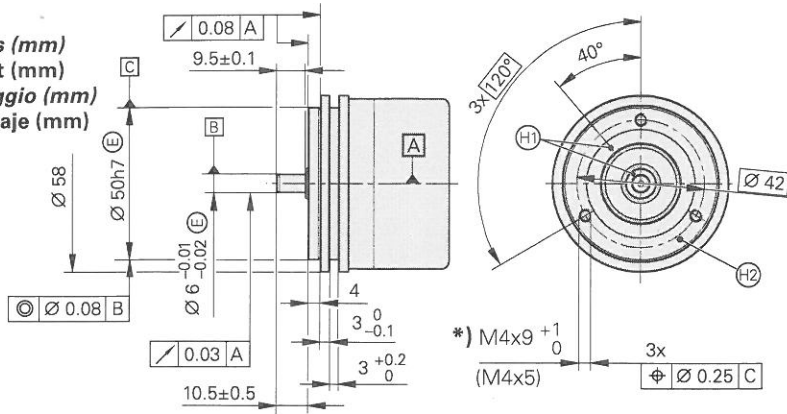

Ⓐ = Lagerung
 Bearing
 Roulement
 Cuscinetto
 Rodamiento

Ⓜ = Referenzmarkenlage Welle - Flansch ±30°
 Reference mark for shaft/flange alignment ±30°
 Marque de référence pour alignement arbre/bride ±30°
 Posizione indice di riferimento per albero - flangia ±30°
 Posición de la marca de referencia eje - brida ±30°

Ⓜ = Messpunkt Arbeitstemperatur
 Measuring point for operating temperature
 Point de mesure température de travail
 Punto di misura - temperatura di esercizio
 Punto de medición de la temperatura de trabajo

***) Umstellung der Gewindelänge von 5 mm auf 9 mm in Umsetzung.**
Change of thread length from 5 mm to 9 mm is currently being implemented.
Changement de la longueur du filet de 5 mm à 9 mm dans la mise en œuvre.
Modifica della lunghezza del filetto in presa da 5 a 9 mm.
Cambio de la longitud de la rosca de 5 mm a 9 mm realizándose.

Anschlussbelegung
Pin Layout
Raccordamenti
Piedinatura
Distribución del conector

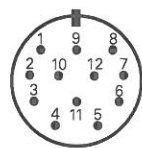
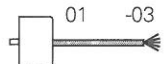

Außenschirm auf Gehäuse
 External shield on housing
 Blindage externe sur boîtier
 Schermo esterno sulla carcassa
 Blindaje externo a carcasa

02S12-03
 03S12-03
 27S12-03
 80S12-03
 7NS12-03

	12	2	10	11	5	6	8	1	3	4	7	/	9
1 V _{SS}	U _P	Sensor U _P	0V	Sensor 0V	A+	A-	B+	B-	R+	R-	/	/	/
TTL HTL	U _P	Sensor U _P	0V	Sensor 0V	U _{a1}	U _{a1}	U _{a2}	U _{a2}	U _{a0}	U _{a0}	U _{aS}	/	/
	BNGN	BU	WHGN	WH	BN	GN	GY	PK	RD	BK	VT	YE	/

Die Sensorleitung ist intern im Messgerät mit der Versorgungsleitung verbunden.
 The sensor line is connected inside the encoder to the supply line.
 La ligne de palpeur est reliée de manière interne dans le système de mesure à la ligne d'alimentation.
 La linea del sensore è collegata internamente allo strumento di misura con la linea di alimentazione.
 La línea de sensor está unida internamente en el aparato de medida con la línea de alimentación.

Montage
Assembly
Montage
Montaggio
Montaje



Achtung: Verletzungsgefahr durch drehende Teile.
 Auf Berührungsschutz achten!
Warning: Risk of injury from rotating parts.
 Protect against contact!
Attention: danger de blessures par des pièces en rotation.
 Prévoir une protection au contact!
Attenzione: pericolo di lesioni da pezzi rotanti.
 Mettere protezioni per impedire il contatto!
Atención: riesgo de accidente por causa de piezas en rotación.
 ¡Considerar una protección ante contacto accidental!

Wellen auf Versatz überprüfen
 Check shafts for offset
 Contrôler le désaxage de l'arbre
 Verificare disallineamento albero
 Controlar desplazamiento del eje

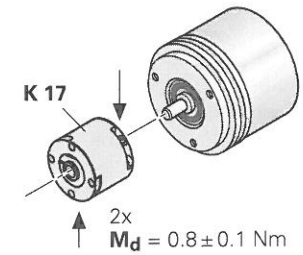
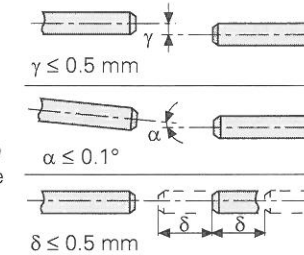

⓪

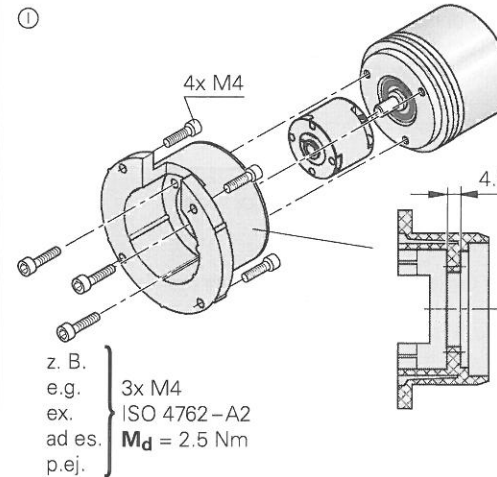

⓪, ① = Anbaumöglichkeiten
 Mounting possibilities
 Options de montage
 Possibilità di montaggio
 Posibilidades de instalación

①

