

$U_p = 5V \pm 10\%$
(I max. 120 mA)



EN 50 178/4.98; 5.2.9.5
IEC 364-4-41: 1992; 411 (PELV/SELV)
(siehe, see, voir, vedi, véase
HEIDENHAIN D 231 929)



A, B, R

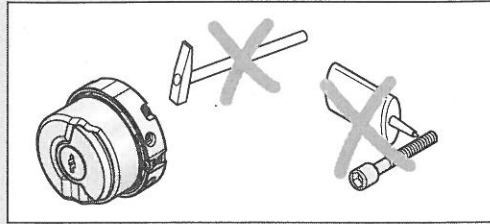
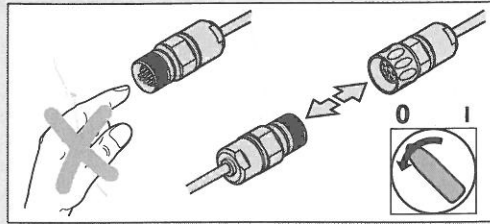
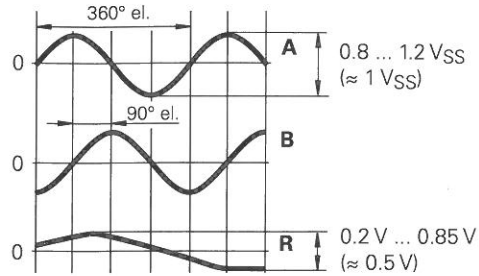

Im Lieferumfang enthalten
Included in delivery
Contenu dans la fourniture
Standard di forniture
Elementos suministrados

Fleckbeschichtung
Patch coating
Enduit autofreinant
Rivestimento
Recubrimiento tintado

M5x25-8.8 DIN 6912
ID 202 264-46



HEIDENHAIN

Montageanleitung
Mounting Instructions
Instructions de montage
Istruzioni di montaggio
Instrucciones de montaje

ERN 1380

11/2007

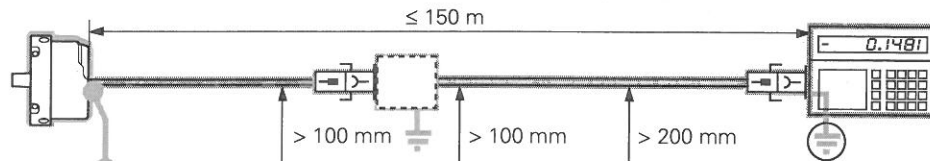

Schirm auf Gehäuse
Shield on housing
Blindage sur boîtier
Schermo sulla carcassa
Blindaje a carcasa

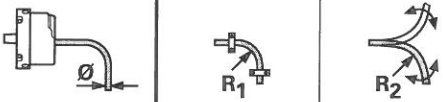
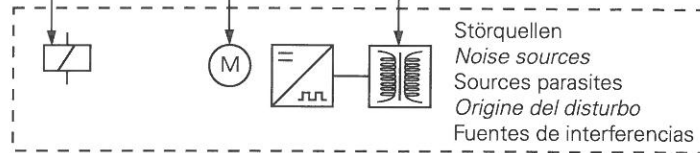

Ø 4.5 mm

$R_1 \geq 18$ mm

/

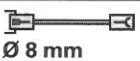

Ø 8 mm

$R_1 \geq 40$ mm

$R_2 \geq 100$ mm

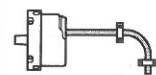
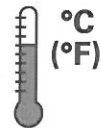

$T \geq -40$ °C
(-40 °F)

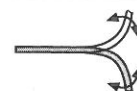

$T \geq -10$ °C
(14 °F)

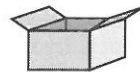

-30 ... 80 °C
(-22 ... 176 °F)

DR. JOHANNES HEIDENHAIN GmbH

Dr.-Johannes-Heidenhain-Straße 5
83301 Traunreut, Germany

☎ +49 (8669) 31-0

FAX +49 (8669) 50 61

E-Mail: info@heidenhain.de

Technical support FAX +49 (8669) 32-1000

Measuring systems ☎ +49 (8669) 31-31 04

E-Mail: service.ms-support@heidenhain.de

TNC support ☎ +49 (8669) 31-31 01

E-Mail: service.nc-support@heidenhain.de

NC programming ☎ +49 (8669) 31-31 03

E-Mail: service.nc-pgm@heidenhain.de

PLC programming ☎ +49 (8669) 31-31 02

E-Mail: service.plc@heidenhain.de

Lathe controls ☎ +49 (8669) 31-31 05

E-Mail: service.lathe-support@heidenhain.de

www.heidenhain.de



Ve 00

631 762-91 · 5 · 1/2008 · H · Printed in Germany · Änderungen vorbehalten

Subject to change without notice · Sous réserve de modifications · Con riserva di modifiche · Sujeto a modificaciones

ERN 1380

Maße in mm
Dimensions in mm
Cotes en mm
Dimensioni in mm
Dimensiones en mm

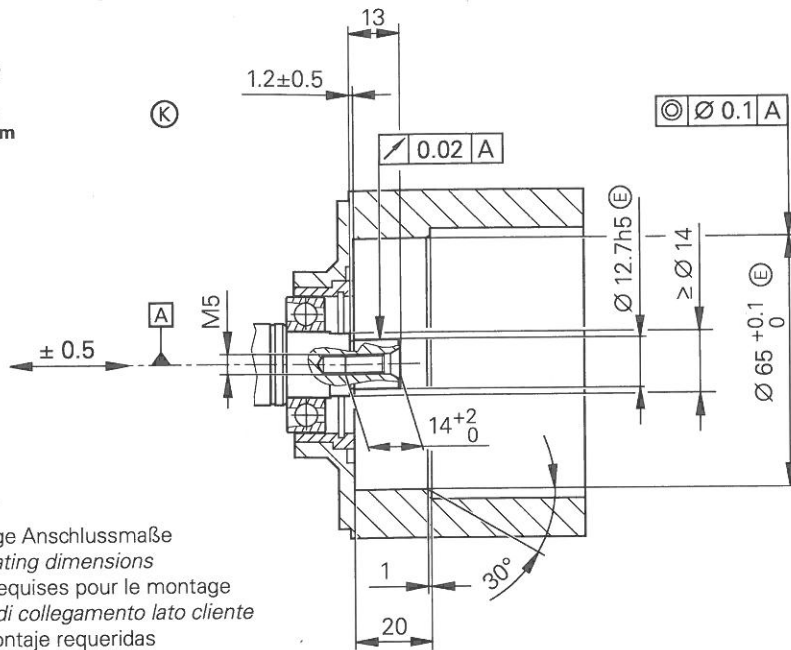

A = Lagerung
Bearing
Roulement
Cuscinetto
Rodamiento

K = Kundenseitige Anschlussmaße
Required mating dimensions
Conditions requises pour le montage
Dimensioni di collegamento lato cliente
Cotas de montaje requeridas

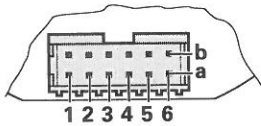

2a	2b	1a	1b	6b	6a	5b	5a	4b	4a	3a, 3b
Up	Sensor 5V	0V	Sensor 0V	A+	A-	B+	B-	R+	R-	/

Die Sensorleitung ist intern mit der Versorgungsleitung verbunden.
The sensor line is connected internally with the power supply.
La ligne de palpeur est reliée de manière interne à la ligne d'alimentation.
La linea del sensore è collegata internamente con la linea di alimentazione.
La línea de sensor está unida internamente con la línea de alimentación.

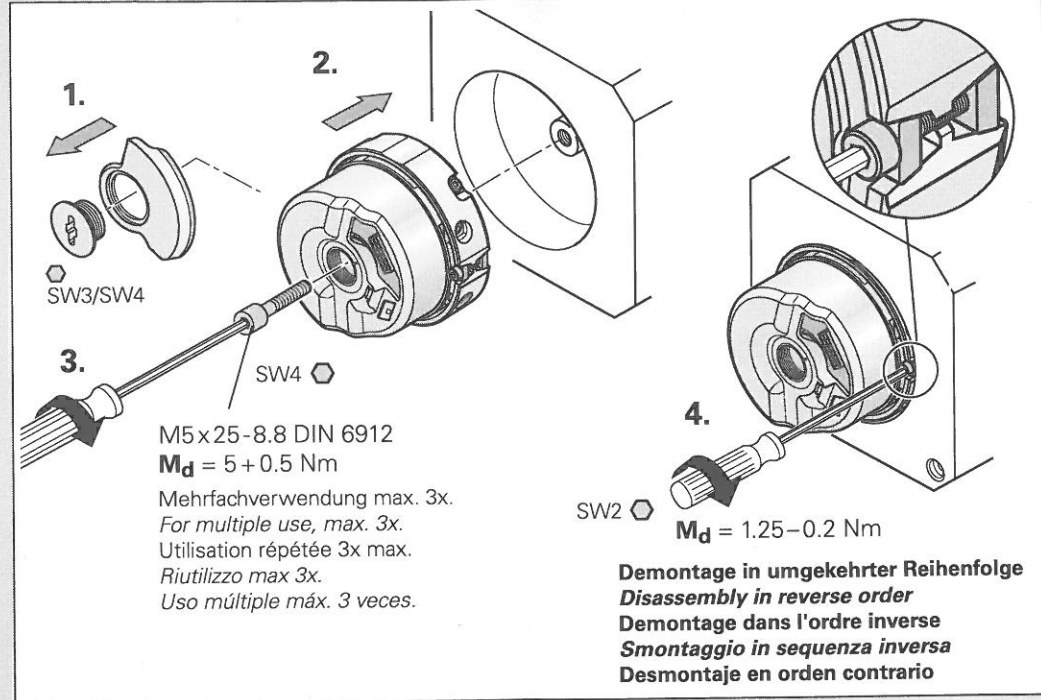

Elektrischen Anschluss herstellen

Electrical connection
Préparer le raccordement électrique
Realizzare il collegamento elettrico
Establecer conexión eléctrica

DIN EN 100 015 - 1
CECC 00015 - 1

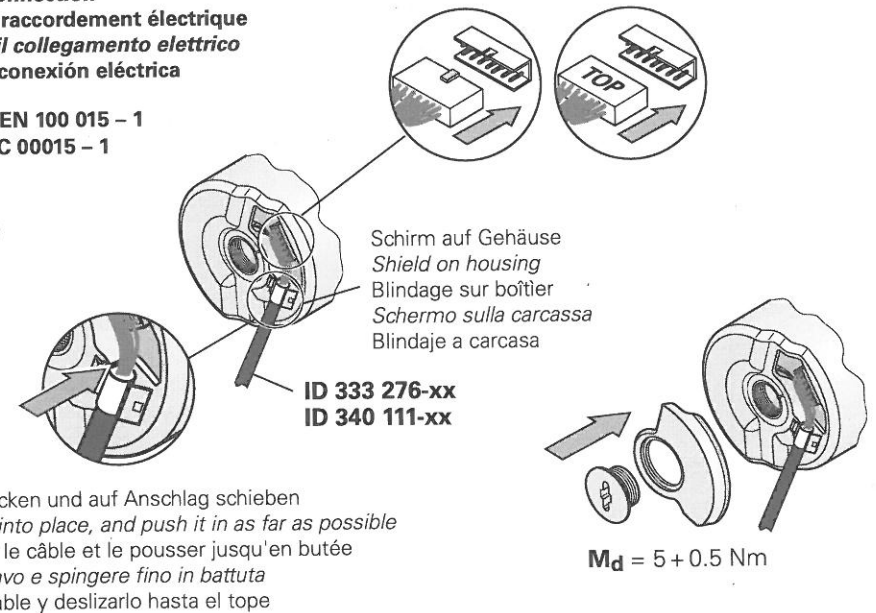
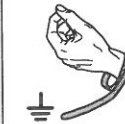

Kabel einlicken und auf Anschlag schieben
Click cable into place, and push it in as far as possible
Encliqueter le câble et le pousser jusqu'en butée
Fissare il cavo e spingere fino in battuta
Doblar el cable y deslizarlo hasta el tope